

Overview

The Gate Control Unit (GCU) can be paired with the Gate Access Panel (GAPLM) to wirelessly control a gate operator.

The GCU is compatible with various Liftmaster Wireless Products.

Carton Inventory

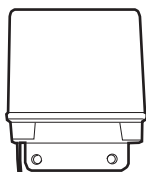

Gate Control Unit (GCU)

Assembly

Step 1

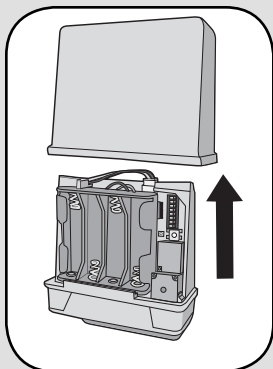

Remove cover.

Step 2

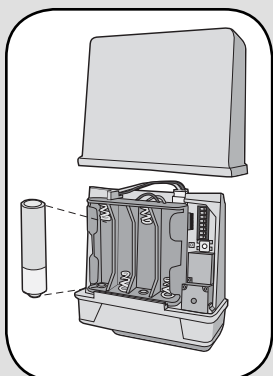

Install 4 AA Alkaline batteries (not provided). (Lithium batteries recommended for colder environments.)

Step 3

NOTE: This step applies only if more than one GCU is being used.

Up to four GCUs can be used. Each GCU will need a different Identity. Set the Identity of the GCU by changing the Dipswitches as shown in the chart below.

GCU ID	Switch #1	Switch #2
1	OFF	OFF
2	ON	OFF
3	OFF	ON
4	ON	ON

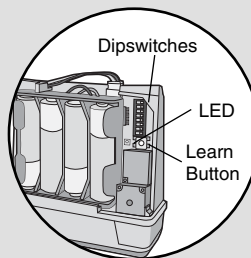

Programming to GAPLM

Step 4

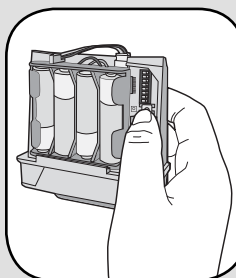

Press the Learn button on the GCU for one second. The LED will light for 20 seconds.

Within 20 seconds enter Master PIN Number on GAPLM:



Followed by GCU Identity as determined in Step 3:



“BEEP” “BEEP”

The GCU LED will blink 3 times indicating programming is successful. If error tone is heard or GCU LED emits 3 double blinks, then programming has failed.

Repeat for additional GCUs.

Installation

Step 5

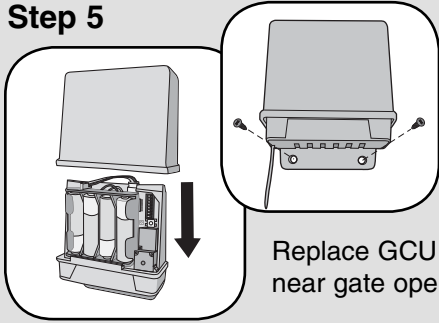

Replace GCU cover and mount near gate operator control box.

Wiring to Gate Operator

Step 6

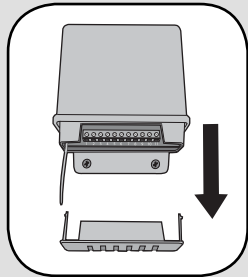

Remove bottom panel of GCU. Connect Terminal 10 on GCU to Common on gate operator (shown below). Connect Terminal 9 to Cycle on gate operator (shown below).

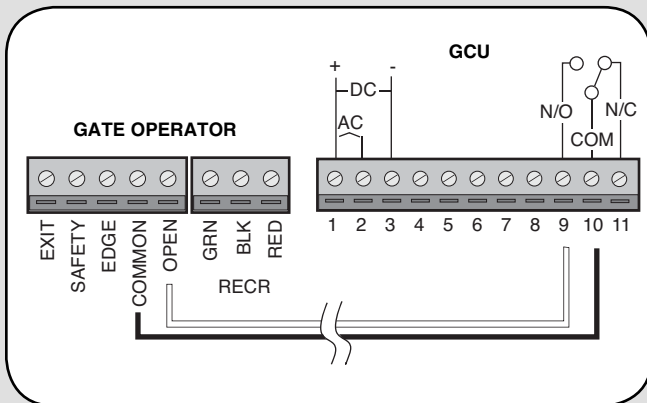

⚠ WARNING

To prevent possible **SERIOUS INJURY** or **DEATH** from electrocution, outputs are suitable **ONLY** for controlling low voltage devices, 24V max, ac or dc.

Operation

Open/Close Gate

To open a gate enter any valid PIN Number on GAPLM. For multiple GCU's, enter the PIN Number followed by the GCU Identity (1-4).

For a remote control transmitter, press the corresponding button for 3 seconds (within 75' of GAPLM).

On an Intercom, press the Remote button while talking to a visitor. At other times, hold the intercom's Remote button for 10 seconds, to activate the Primary GCU.

NOTE: If the gate operator is not set to automatically close the gate, any of the above methods can be repeated to close the gate.

Gate Terminals

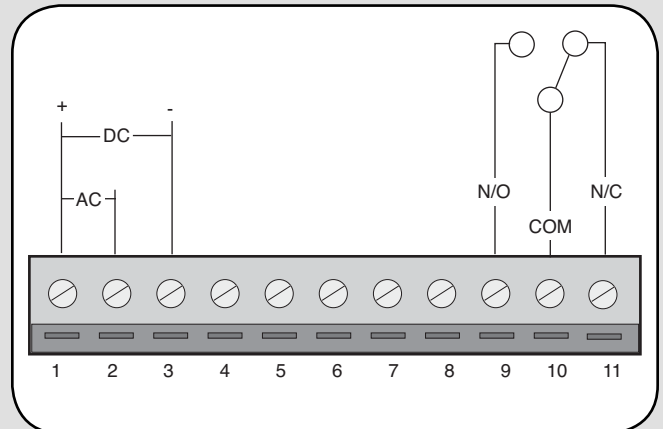

Optional Power Inputs:

- Terminals 1 and 2: Optional 10-24 Vac power input.
 - Terminals 1 and 3: Optional 9-24 Vdc power input.
- Ensure that the gate's DC power supply "Ground" is wired to terminal 3.

Relay Outputs:

- Terminal 9: Relay Normally Open contact.
- Terminal 10: Relay Common.
- Terminal 11: Relay Normally Closed contact.

Relay connections typically wire to Open Gate input on gate operator.

NOTE: Output switching capacity is low voltage (24V max, ac or dc).

Unused Contacts:

- Terminals 4-8: Not used.

Gate Operator “ON” Time

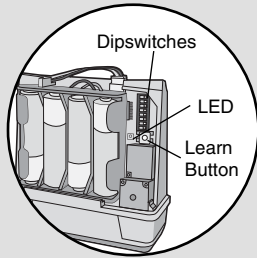

For most connections the default setting of 1/2 second is best. However, for connection to low voltage yard lights, cameras, etc. the device can be adjusted as to how long it stays on.

NOTE: Output switching capacity is low voltage (24V max, ac or dc).

“ON” Time	Switch #3	Switch #4
1/2 second	OFF	OFF
1/2 second	ON	OFF
10 seconds	OFF	ON
30 seconds	ON	ON

NOTE: For most gate system wiring, dipswitch #4 should be left “OFF”.

Open Gate Configuration

Use this configuration when using the Gate System as an open-only system, which automatically closes, based on timer or a magnetic loop.

Enable the Auto-close feature on Gate Operator. Connect the GCU as shown in *Wiring to Operator* section. Refer to product-specific manual for wiring information. On the Intercom, disable Gate Status checking.

Troubleshooting

There is an error tone when the GCU is activated.
The GAPLM or DAILM is not communicating with the GCU. The GCU may be out of range. If the units work properly when close together, the GCU may need to be mounted higher off the ground or on a different surface. Metal, trees, or masonry cause the most interference.

If the units do not work when close together, the GAPLM or DAILM has not been programmed to the GCU. Double-check the GCU’s Identity (1-4) and reprogram it.

Memory needs to be cleared.

Hold down the Learn button until the LED blinks a total of 8 times.

FOR TECHNICAL SUPPORT DIAL OUR TOLL FREE NUMBER:

1-800-528-2806

www.liftmaster.com

NOTICE: To comply with FCC and or Industry Canada rules (IC), adjustment or modifications of this receiver and/or transmitter are prohibited, except for changing the code setting or replacing the battery. THERE ARE NO OTHER USER SERVICEABLE PARTS.
Tested to Comply with FCC Standards FOR HOME OR OFFICE USE. Operation is subject to the following two conditions: (1) this device may not cause harmful interference, and (2) this device must accept any interference received, including interference that may cause undesired operation.