

**STEP 1-A**

REMOVE EXISTING BELT. MOUNT NEW PLATE ON CHASSIS. BOLT IN PLACE (AS SHOWN) WITH BOLTS PROVIDED.

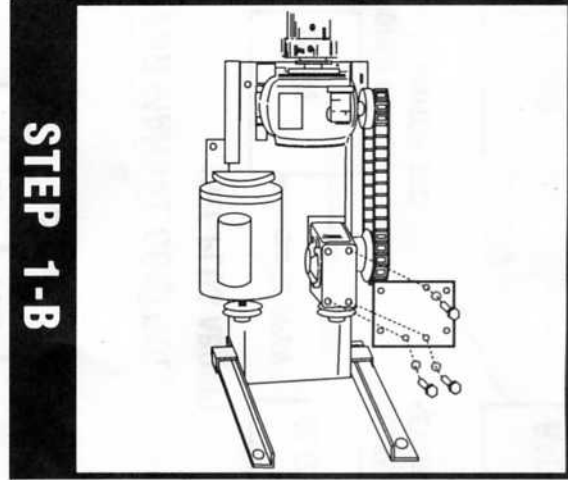

**STEP 1-B**

OR

REMOVE EXISTING BELT. MOUNT NEW PLATE ON LOWER GEARBOX. BOLT IN PLACE (AS SHOWN) WITH BOLTS PROVIDED.

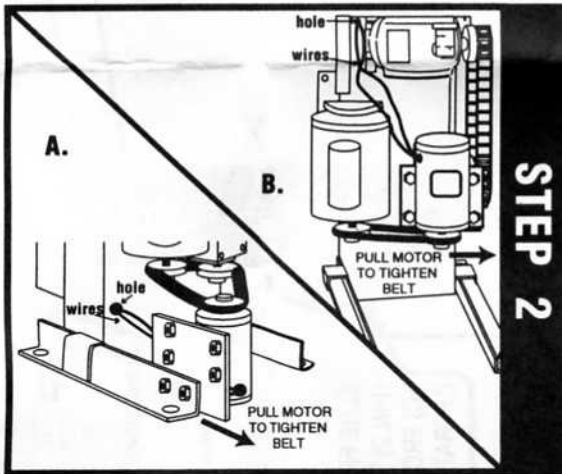

**STEP 2**

BOLT DC MOTOR TO PLATE OF STEP 1A OR 1B. PUT NEW BELT IN PLACE AROUND PULLEYS. MAKE SURE PULLEYS ARE IN LINE. PULL MOTOR TO TIGHTEN BELT, THEN FINISH TIGHTENING BOLTS. PUT TWO WIRES FROM NEW MOTOR THROUGH APPROPRIATE HOLE IN CHASSIS AS SHOWN.

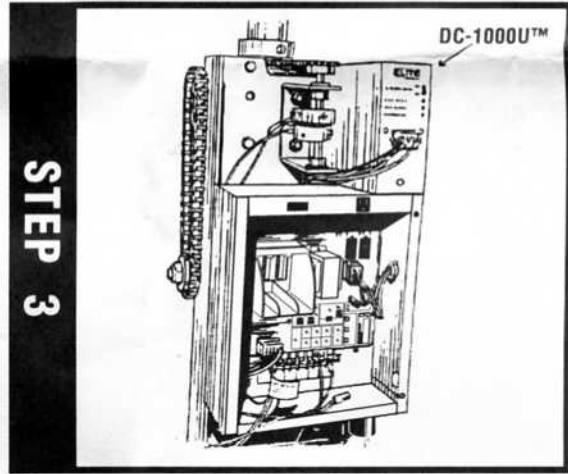

**STEP 3**

PLACE DC-1000U™ UNIT ON TOP OF MAIN CONTROL BOX AND INSTALL TWO WIRES FROM BACK OF DC-1000U™ TO TWO WIRES FROM 12V MOTOR, USING WIRE NUTS PROVIDED. (CROSSING WIRES WILL CHANGE THE DIRECTION THE DC-1000U™ WILL OPEN.)

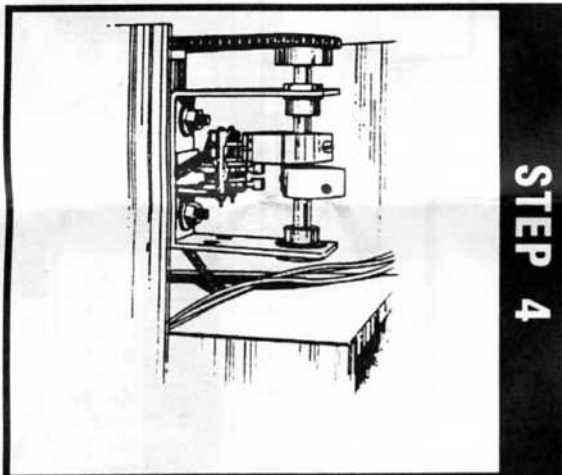

**STEP 4**

CONNECT EXTRA LIMIT SWITCHES TO WIRES FROM DC-1000U™ PER WIRING DIAGRAM ON BACK OF THIS SHEET.

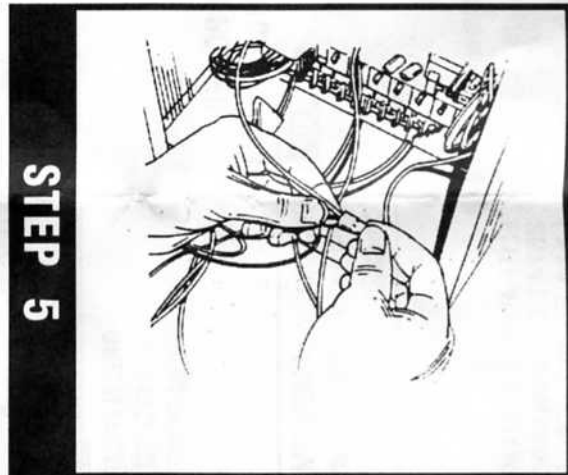

**STEP 5**



**CAUTION: DO NOT CONNECT 120V AC TO DC-1000U™.** CONNECT THE HOT WIRE FROM THE POWER SOURCE TO THE BLACK WIRE FROM THE DC-1000U™, THEN THE BLUE WIRE FROM THE DC-1000U™ TO THE BLACK WIRE ON THE OPERATOR.

